

# Marbul rec 2xLED GE

142222XX\_142223XX

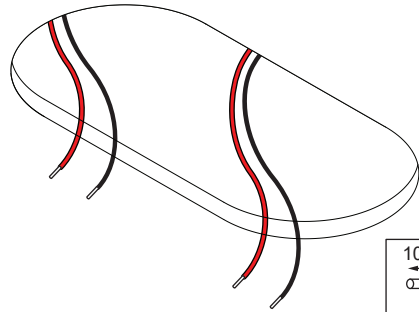

10mm  
□ 0,08 - 2,5mm<sup>2</sup>

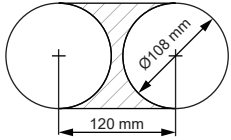
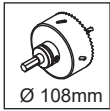

Drive Current (mA)	Forward Voltage		Power (W)
	min (Vf)	max (Vf)	
350	15,3	19,3	6,0
500	15,8	19,8	8,9

For serial connection, respect polarity!

⊕ RED      ⊖ BLACK

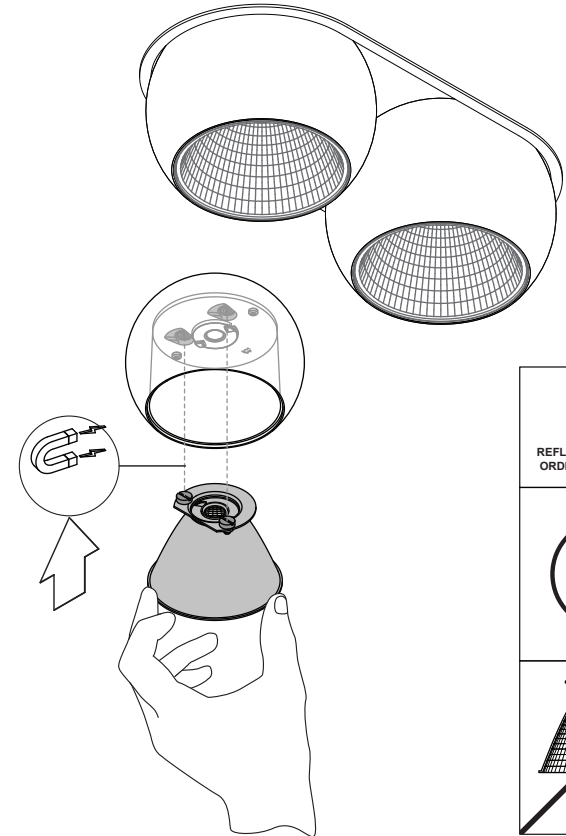
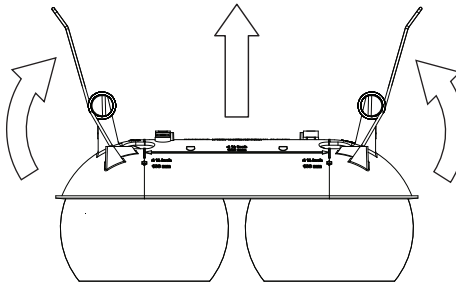
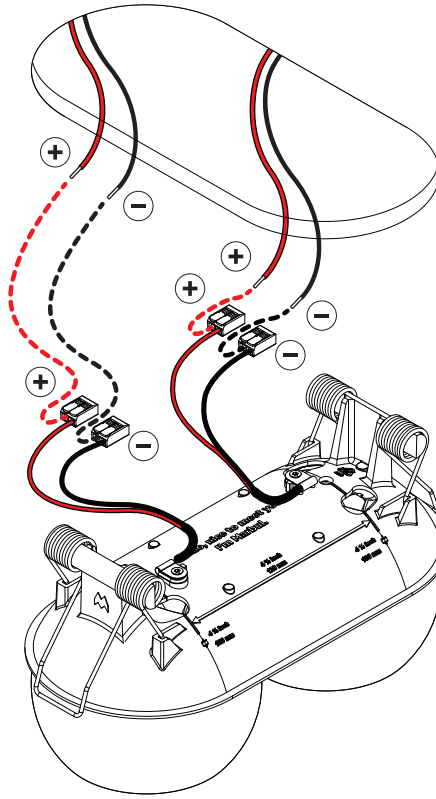
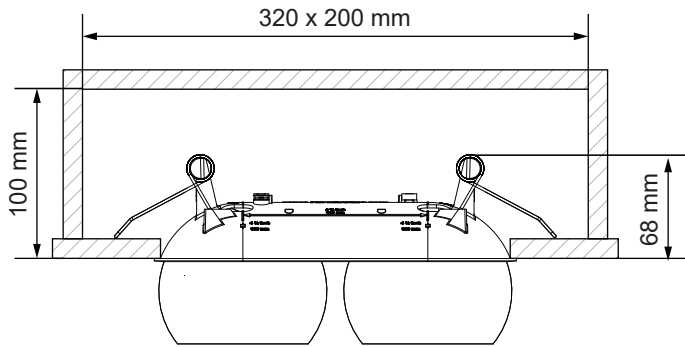

**LIGHT SOURCE - DO NOT TOUCH LED**

Touching the LED can result in permanent damage of the light source. The light source contained in this luminaire shall only be replaced by the manufacturer or his service agent or a similar qualified person.

**PREVENTING ELECTROSTATIC DAMAGE**

A discharge of static electricity may damage sensitive components. Always be properly grounded when touching leads or circuitry inside the luminaire. Use a wrist strap connected by a ground cord to the housing. Avoid touching the light sources with bare hands.

**DRIVERS & ACCESSORIES**

For latest version of driver matrix and available accessories check [www.supermodular.com](http://www.supermodular.com) or connect with your sales contact.

